

AM - Docentes
Esc. 1 : 25

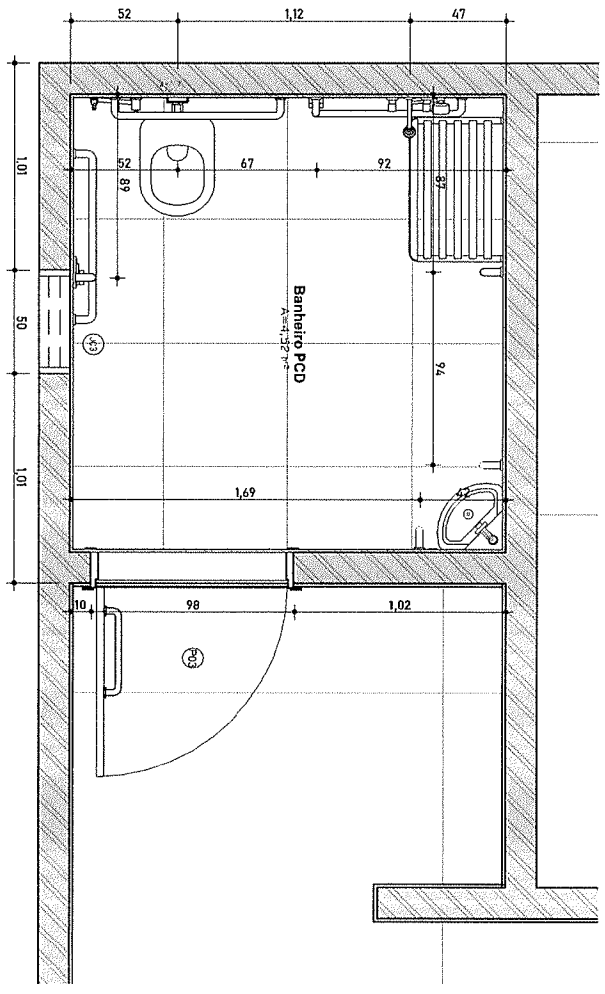

AM - BWR AEE
Esc. 1 : 25

Obr.: REFORMA E AMPLIAÇÃO DA ESCOLA JOSÉ HAMILTON

Desenho: Alysson Costa

Localização: RUA RAIMUNDO CRAVEIRO - LUIZ ALVES

Revisão:

Responsável Técnico

João Uilson Sarinva Cruz
Secretário Municipal de Projetos Urbanísticos e Habitação

Projeto: ESCOLA JOSÉ HAMILTON

Data: 30/01/2024



SECRETARIA MUNICIPAL DE PROJETOS URBANÍSTICOS E HABITAÇÃO ESPECIAL
SEPURB

Prancha
PE11
4.4

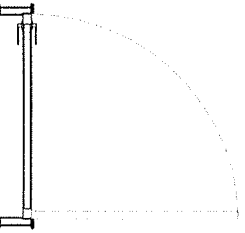
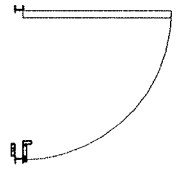
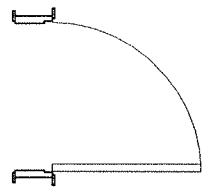
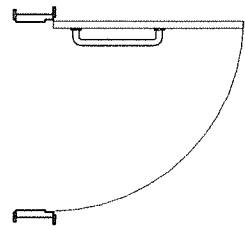
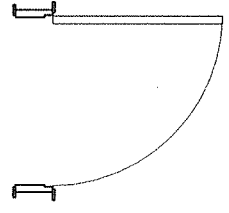
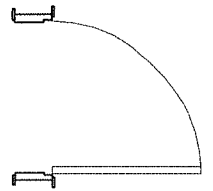
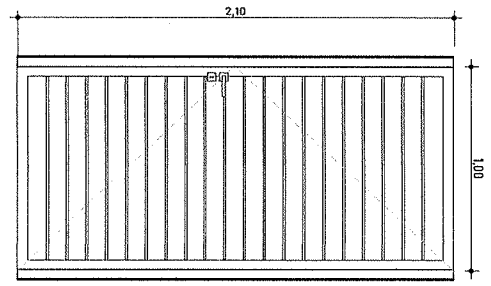
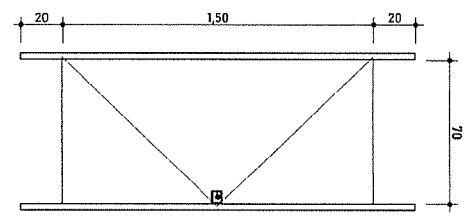
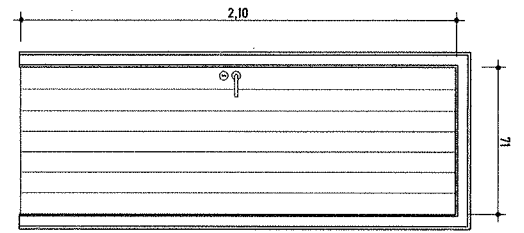
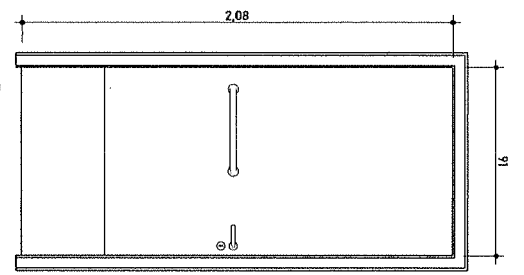
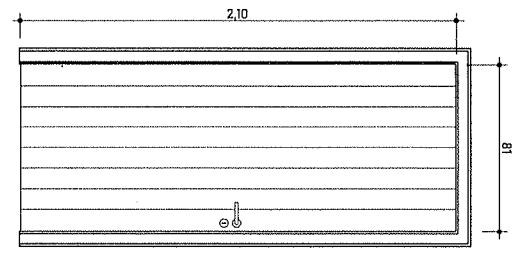
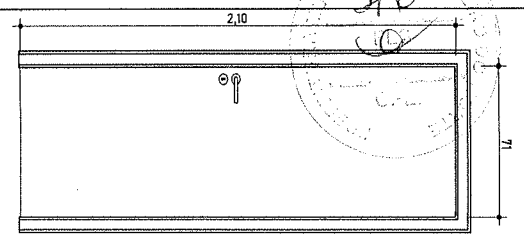
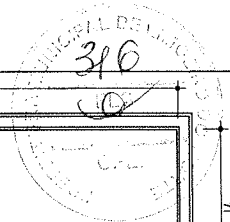

P01
ESC: 1:25

P02
ESC: 1:25

P03
ESC: 1:25

P04
ESC: 1:25

P05
ESC: 1:25

P06
ESC: 1:25

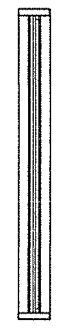
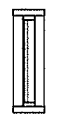
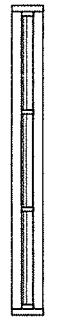
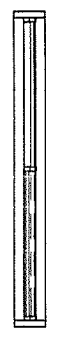
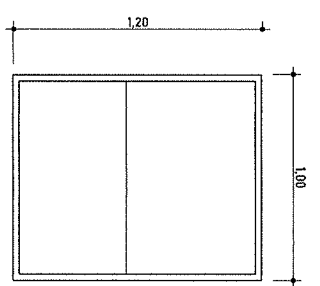
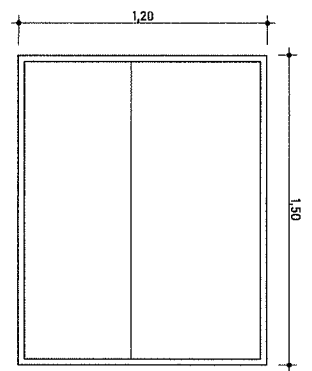
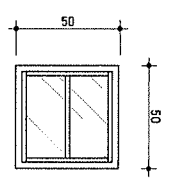
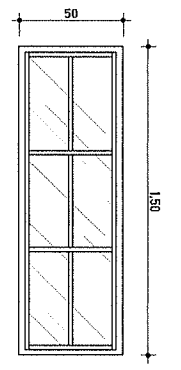
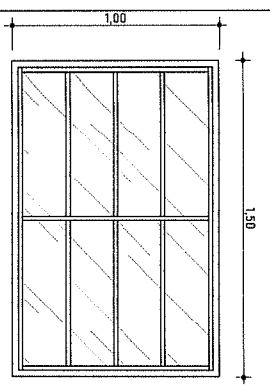

J01
ESC: 1:25

J02
ESC: 1:25

J03
ESC: 1:25

J04
ESC: 1:25

J05
ESC: 1:25

Obra: REFORMA E AMPLIAÇÃO DA ESCOLA JOSÉ HAMILTON

Localização: RUA RAIMUNDO CRAVEIRO - LUIZ ALVES

Projeto: ESCOLA JOSÉ HAMILTON

Assessor:

Desenho: Alysson Costa

Revisão:

Data: 30/01/2024

Escala:

[Handwritten Signature]

Responsável Técnico

João Uldison Saraiva Cruz
Secretário Municipal de Projetos Urbanísticos e Habitação



SECRETARIA MUNICIPAL DE PROJETOS URBANÍSTICOS E HABITAÇÃO SOCIAL
SEPURB

Prancha: PE13

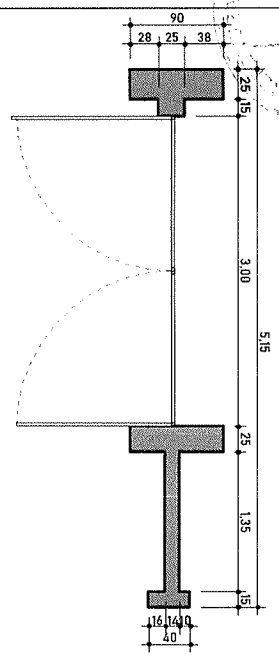
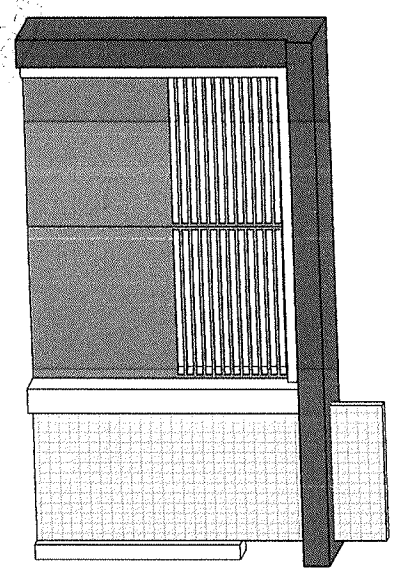
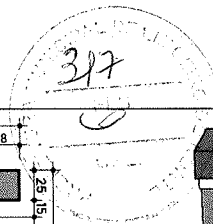

Planta Baixa
ESC: 1 : 50

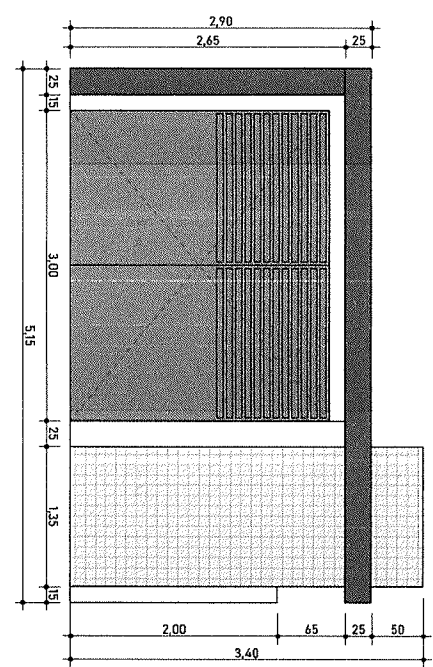
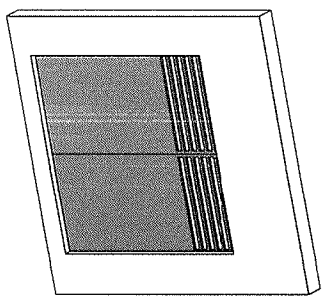

Elevação Frontal
ESC: 1 : 50

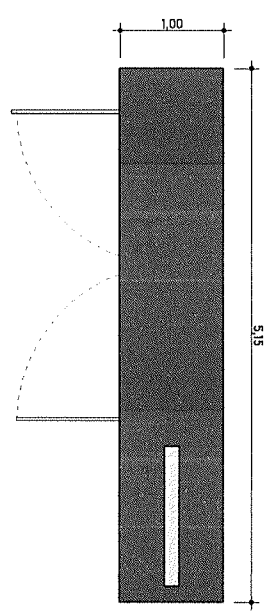

Elevação Topo
ESC: 1 : 50

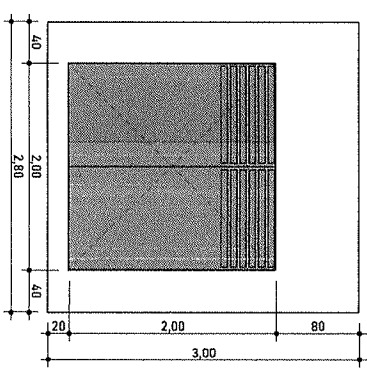

Elevação frontal
ESC: 1 : 50

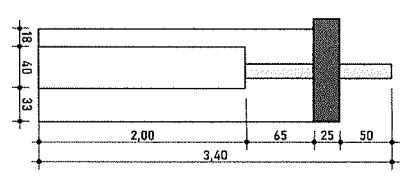

Elevação Esquerda
ESC: 1 : 50

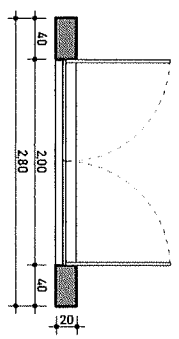

Planta Baixa
ESC: 1 : 50

Obra: REFORMA E AMPLIAÇÃO DA ESCOLA JOSÉ HAMILTON

Desenho: Alysson Costa

Localização: RUA RAIMUNDO CRAVEIRO - LUIZ ALVES

Revisão:

Responsável Técnico

João Uidson Saraiva Cruz
Secretário Municipal de Projetos Urbanísticos e Habitação

Projeto: ESCOLA JOSÉ HAMILTON

Data: 30/01/2024

Assunto:

Escala:



Prancha: PE14
14

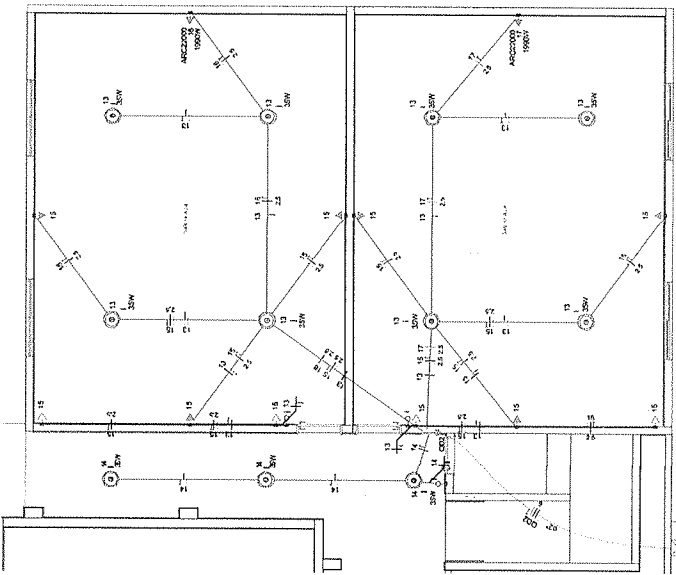

FIACÃO - PAVIMENTO TÉRREO - BLOCO 02
1:100

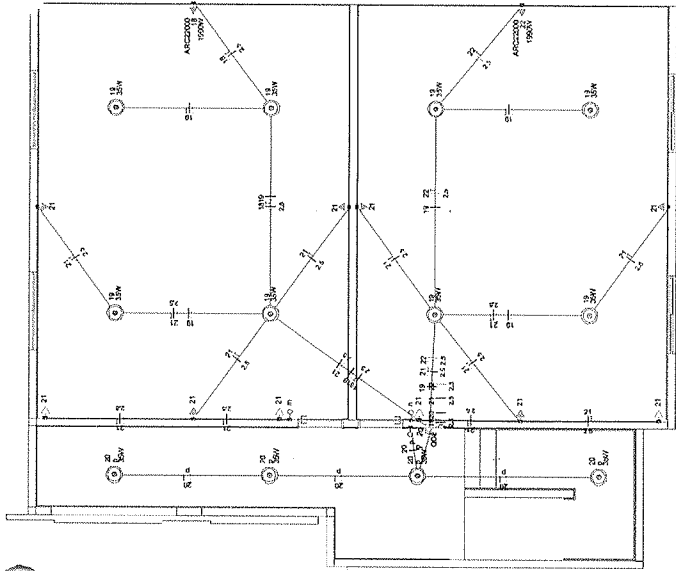

FIACÃO - PAVIMENTO SUPERIOR - BLOCO 02
1:100



DIAGRAMA MULTIFILAR BLOCO 02
1:200



Observação: Estas atividades foram desenvolvidas no local e por profissionais habilitados e autorizados pelo autor.

Responsável Técnico: JOSÉ MATEUS DE SOUZA JUNIOR
RUA: AV. CARLOS DE CARVALHO, 150 - JARDIM SÃO CARLOS - SÃO PAULO - SP - 05508-000

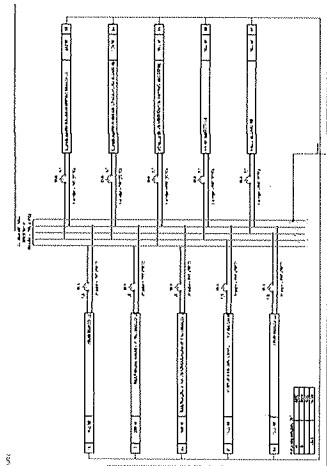
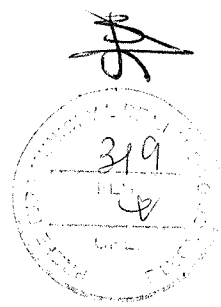
Projeto: REFORMA E AMPLIAÇÃO ESCOLA JOSÉ MATEUS DE SOUZA JUNIOR
PROJETO ELÉTRICO - BLOCO 02

Arquiteto: JOSÉ MATEUS DE SOUZA JUNIOR
RUA: AV. CARLOS DE CARVALHO, 150 - JARDIM SÃO CARLOS - SÃO PAULO - SP - 05508-000

Engenheiro: JOSÉ MATEUS DE SOUZA JUNIOR
RUA: AV. CARLOS DE CARVALHO, 150 - JARDIM SÃO CARLOS - SÃO PAULO - SP - 05508-000

Projeto Elétrico: JOSÉ MATEUS DE SOUZA JUNIOR
RUA: AV. CARLOS DE CARVALHO, 150 - JARDIM SÃO CARLOS - SÃO PAULO - SP - 05508-000

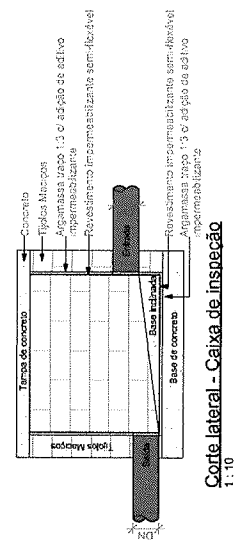
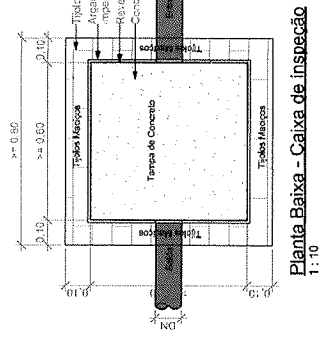
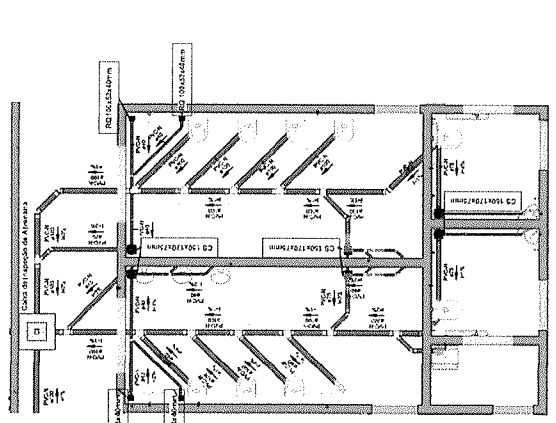
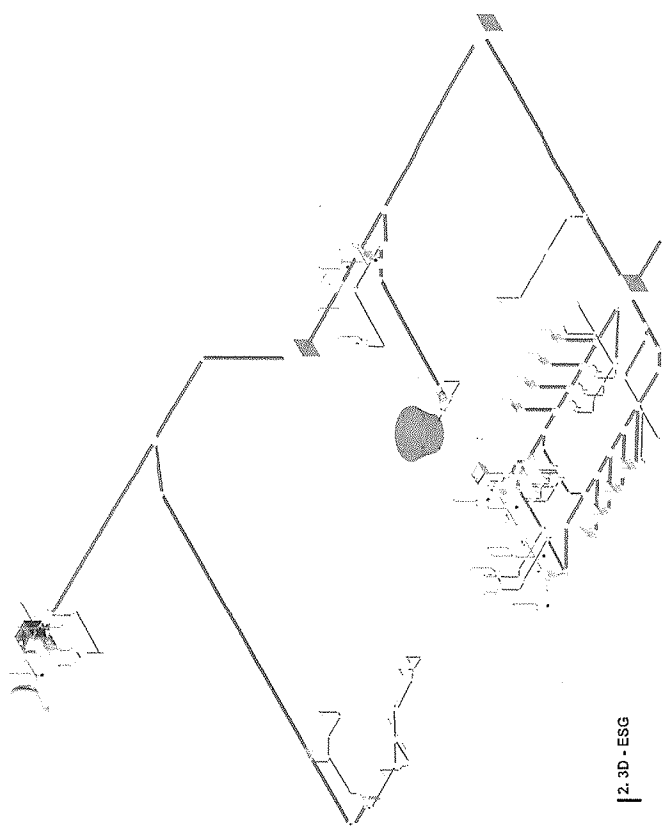
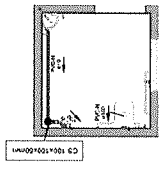
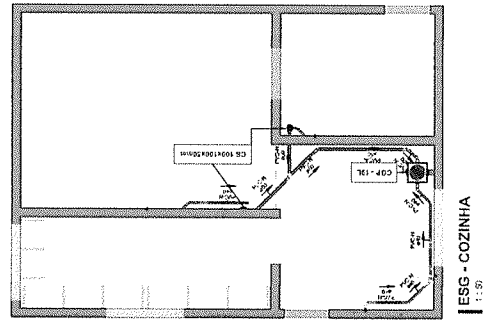
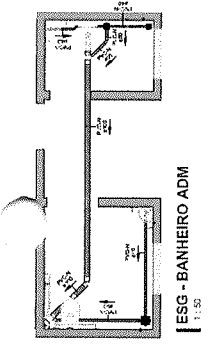
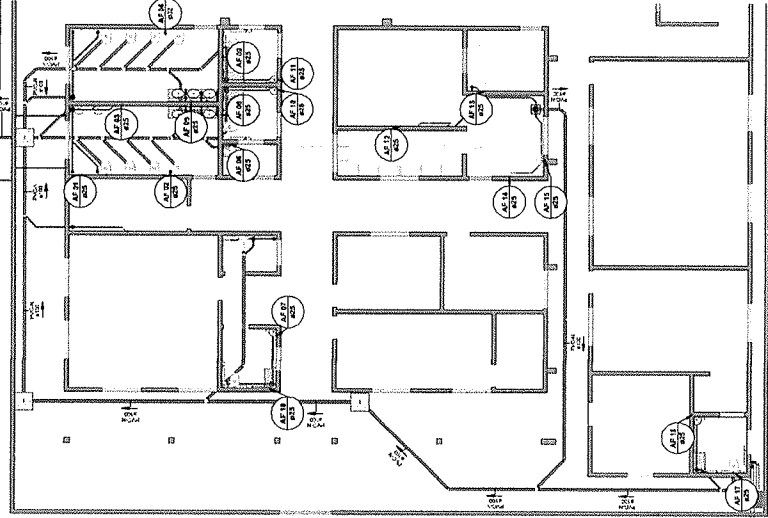

Símbolo	Conteúdo
	Tubulação vertical Aprovada para a instalação de esgoto aprovada dentro (E.C., A.F.T.) ou fora um diâmetro na coluna A.F.T. e no ponto de cabura, sempre que ocorrer uma subida em relação à direção do tubo. Quando houver "F", significa que ocorreu um desvio.
	Tubo de Quebra (n = número da coluna)
	Coluna de Ventilação (n = número da coluna)
	Coluna de Água Fria (n = número da coluna)
	Coluna de Água Quente (n = número da coluna)
	DH, sentido do escoamento e material do tubo
	Código de acessórios do tubo E = tipo de espuma F = Água fria n = número

Observação:
Essas simbologias devem ser utilizadas no local
de projeto e no momento da execução do obra.

Handwritten signature



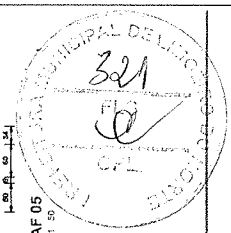
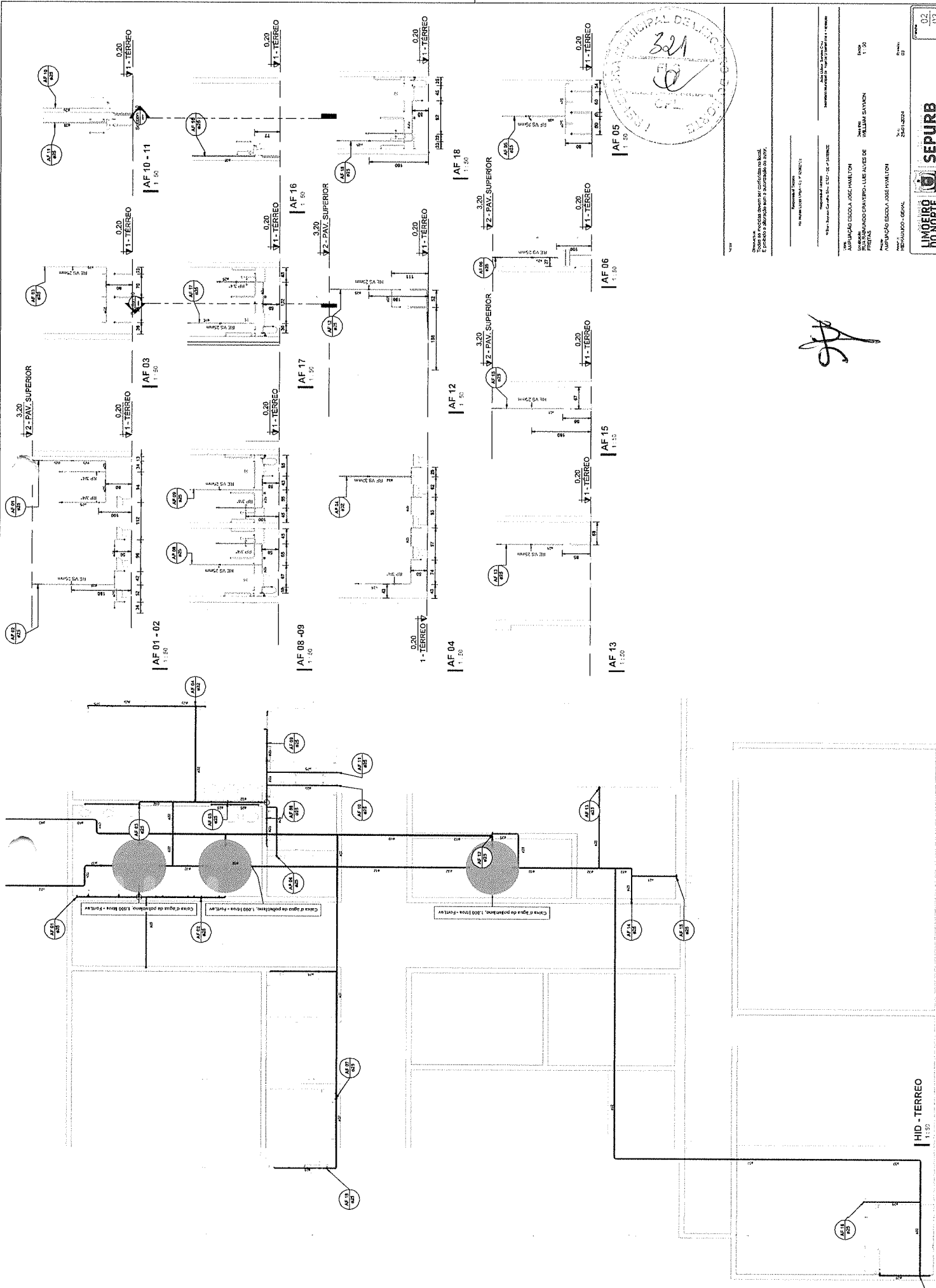

Handwritten signature

Este projeto foi elaborado em conformidade com o Regulamento Municipal de Urbanização e Edificação do Município de Limoeiro do Norte.

PROFESSOR: **ALVARO CESAR DA SILVA**
 TÍTULO: **PROFESSOR**
 Nº DE REGISTRO: **17.20**
 INSTITUIÇÃO: **INSTITUTO DE EDUCAÇÃO SUPERIOR DE LIMOEIRO DO NORTE**
 ENDEREÇO: **RUA JOSÉ MARQUES, 100 - JARDIM SANTA TEREZINHA - LIMOEIRO DO NORTE - RN**
 CEP: **59.100-000**
 TELEFONE: **(35) 3333-1111**
 E-MAIL: **alvaro@iesl.com.br**

LIMOEIRO DO NORTE
SEPURB
 SECRETARIA MUNICIPAL DE URBANIZAÇÃO E EDIFICAÇÃO
 Rua José Marques, 100 - Jardim Santa Teresinha - Limoeiro do Norte - RN
 CEP: 59.100-000
 Telefone: (35) 3333-1111
 E-mail: sepurb@limoeirodo-norte.com.br

HID - TERREO
 1:50

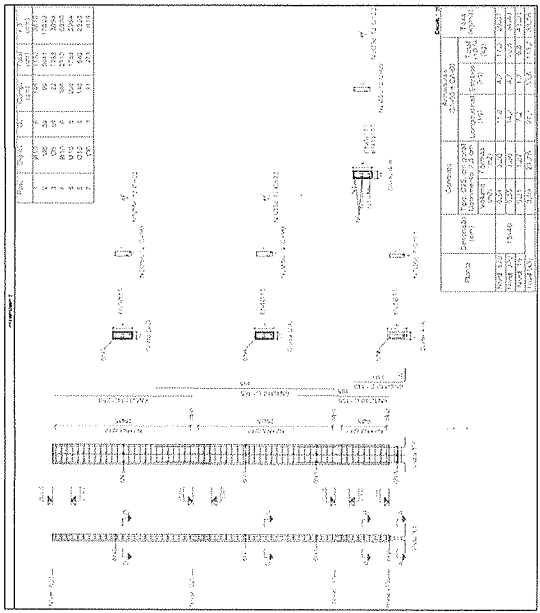

Segmento	Manhole	Top (m)	Bottom (m)	Length (m)	Material	Diâmetro (mm)	Velocidade (m/s)	Q (l/s)
1	1	1.00	0.80	10	Concrete	150	0.8	1.5
2	2	1.10	0.90	10	Concrete	150	0.8	1.5
3	3	1.20	1.00	10	Concrete	150	0.8	1.5
4	4	1.30	1.10	10	Concrete	150	0.8	1.5
5	5	1.40	1.20	10	Concrete	150	0.8	1.5
6	6	1.50	1.30	10	Concrete	150	0.8	1.5
7	7	1.60	1.40	10	Concrete	150	0.8	1.5
8	8	1.70	1.50	10	Concrete	150	0.8	1.5
9	9	1.80	1.60	10	Concrete	150	0.8	1.5
10	10	1.90	1.70	10	Concrete	150	0.8	1.5

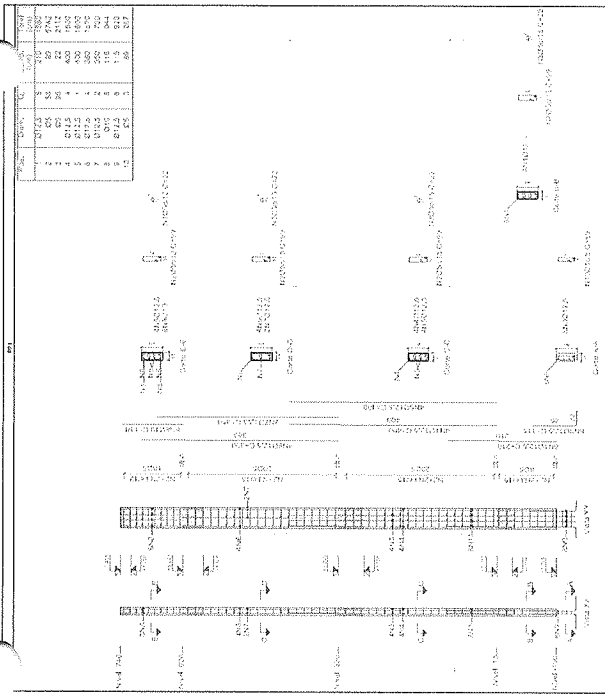

Segmento	Manhole	Top (m)	Bottom (m)	Length (m)	Material	Diâmetro (mm)	Velocidade (m/s)	Q (l/s)
1	1	1.00	0.80	10	Concrete	150	0.8	1.5
2	2	1.10	0.90	10	Concrete	150	0.8	1.5
3	3	1.20	1.00	10	Concrete	150	0.8	1.5
4	4	1.30	1.10	10	Concrete	150	0.8	1.5
5	5	1.40	1.20	10	Concrete	150	0.8	1.5
6	6	1.50	1.30	10	Concrete	150	0.8	1.5
7	7	1.60	1.40	10	Concrete	150	0.8	1.5
8	8	1.70	1.50	10	Concrete	150	0.8	1.5
9	9	1.80	1.60	10	Concrete	150	0.8	1.5
10	10	1.90	1.70	10	Concrete	150	0.8	1.5

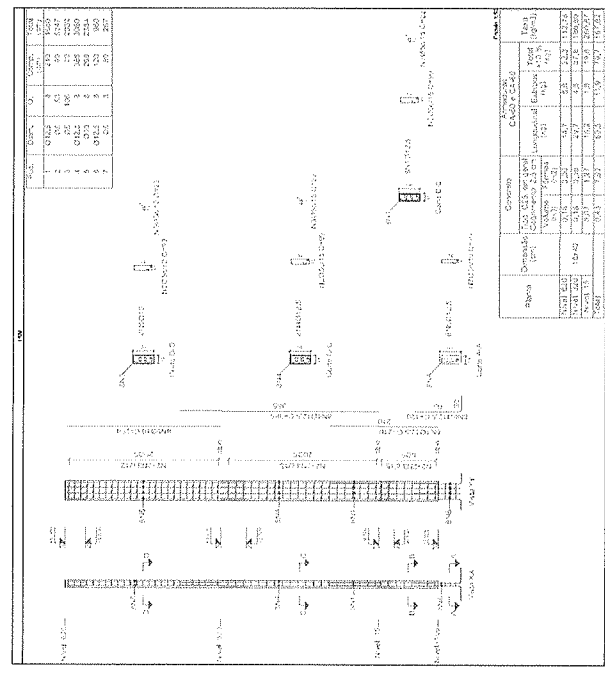

Segmento	Manhole	Top (m)	Bottom (m)	Length (m)	Material	Diâmetro (mm)	Velocidade (m/s)	Q (l/s)
1	1	1.00	0.80	10	Concrete	150	0.8	1.5
2	2	1.10	0.90	10	Concrete	150	0.8	1.5
3	3	1.20	1.00	10	Concrete	150	0.8	1.5
4	4	1.30	1.10	10	Concrete	150	0.8	1.5
5	5	1.40	1.20	10	Concrete	150	0.8	1.5
6	6	1.50	1.30	10	Concrete	150	0.8	1.5
7	7	1.60	1.40	10	Concrete	150	0.8	1.5
8	8	1.70	1.50	10	Concrete	150	0.8	1.5
9	9	1.80	1.60	10	Concrete	150	0.8	1.5
10	10	1.90	1.70	10	Concrete	150	0.8	1.5

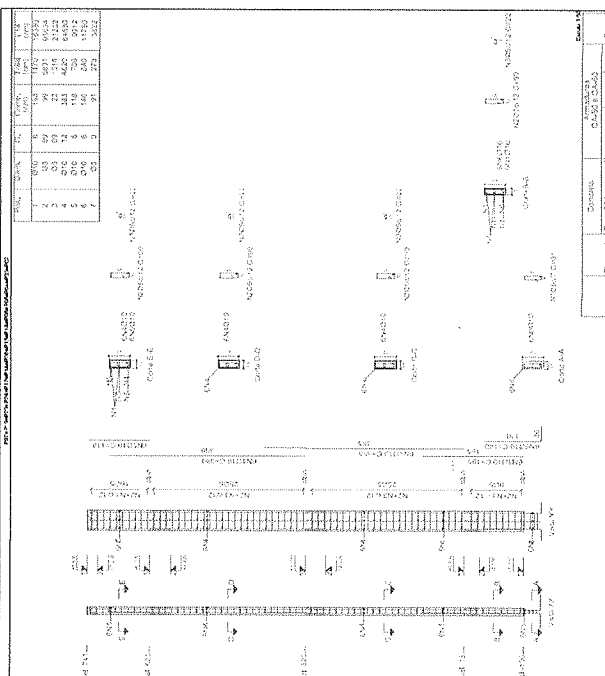

Segmento	Manhole	Top (m)	Bottom (m)	Length (m)	Material	Diâmetro (mm)	Velocidade (m/s)	Q (l/s)
1	1	1.00	0.80	10	Concrete	150	0.8	1.5
2	2	1.10	0.90	10	Concrete	150	0.8	1.5
3	3	1.20	1.00	10	Concrete	150	0.8	1.5
4	4	1.30	1.10	10	Concrete	150	0.8	1.5
5	5	1.40	1.20	10	Concrete	150	0.8	1.5
6	6	1.50	1.30	10	Concrete	150	0.8	1.5
7	7	1.60	1.40	10	Concrete	150	0.8	1.5
8	8	1.70	1.50	10	Concrete	150	0.8	1.5
9	9	1.80	1.60	10	Concrete	150	0.8	1.5
10	10	1.90	1.70	10	Concrete	150	0.8	1.5

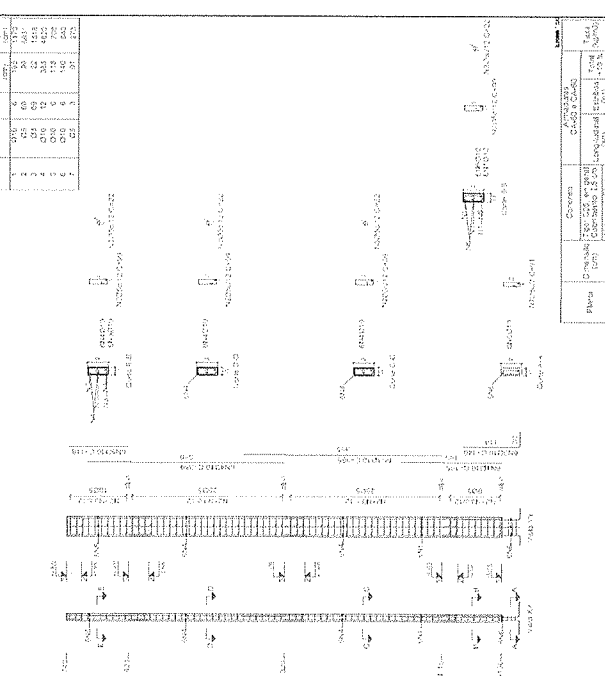

Segmento	Manhole	Top (m)	Bottom (m)	Length (m)	Material	Diâmetro (mm)	Velocidade (m/s)	Q (l/s)
1	1	1.00	0.80	10	Concrete	150	0.8	1.5
2	2	1.10	0.90	10	Concrete	150	0.8	1.5
3	3	1.20	1.00	10	Concrete	150	0.8	1.5
4	4	1.30	1.10	10	Concrete	150	0.8	1.5
5	5	1.40	1.20	10	Concrete	150	0.8	1.5
6	6	1.50	1.30	10	Concrete	150	0.8	1.5
7	7	1.60	1.40	10	Concrete	150	0.8	1.5
8	8	1.70	1.50	10	Concrete	150	0.8	1.5
9	9	1.80	1.60	10	Concrete	150	0.8	1.5
10	10	1.90	1.70	10	Concrete	150	0.8	1.5

Nome: _____
 Data: _____
 Escala: _____
 Projeto: _____
 Autor: _____
 Aprovado: _____
 Data: _____

LÍMPOEIRO DO NORTE
 SANEAMENTO BÁSICO
 SEPURB

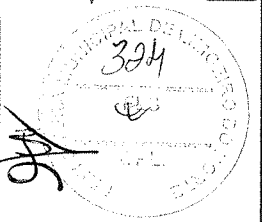
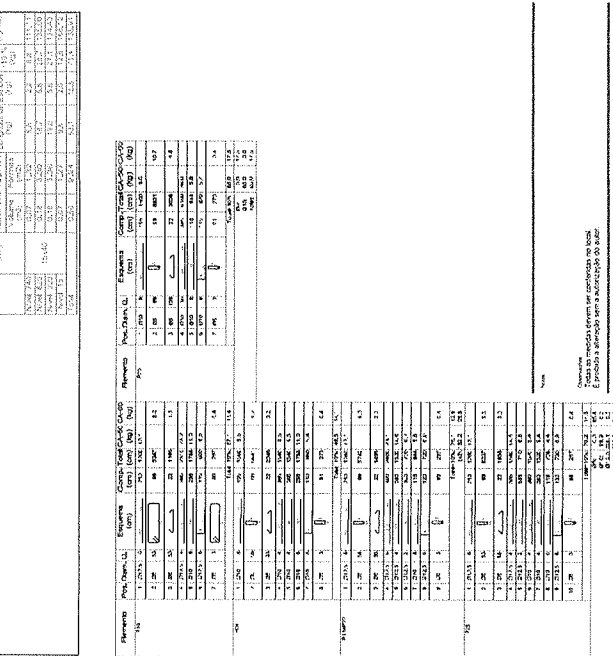
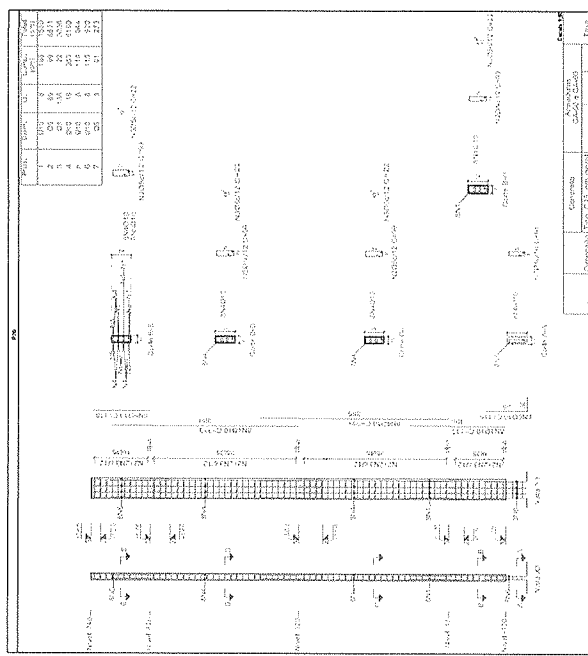
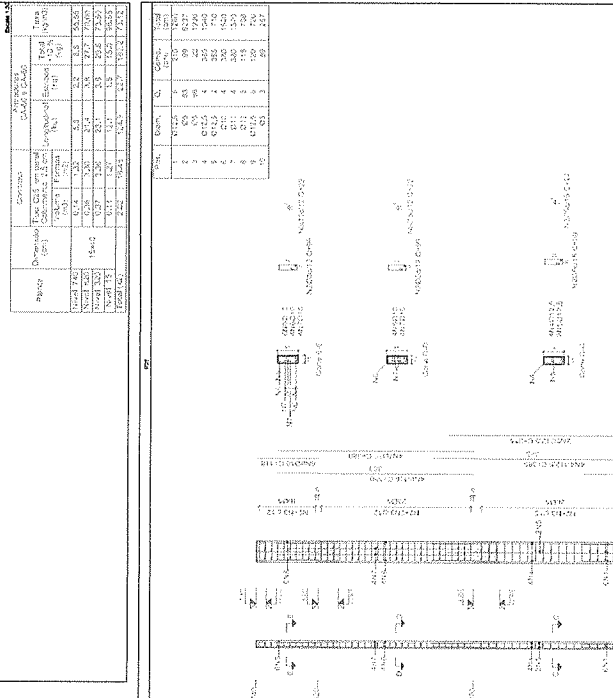
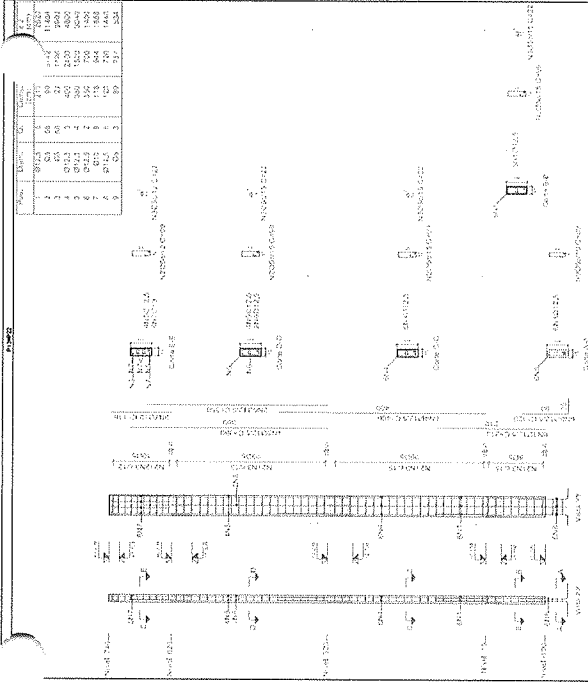
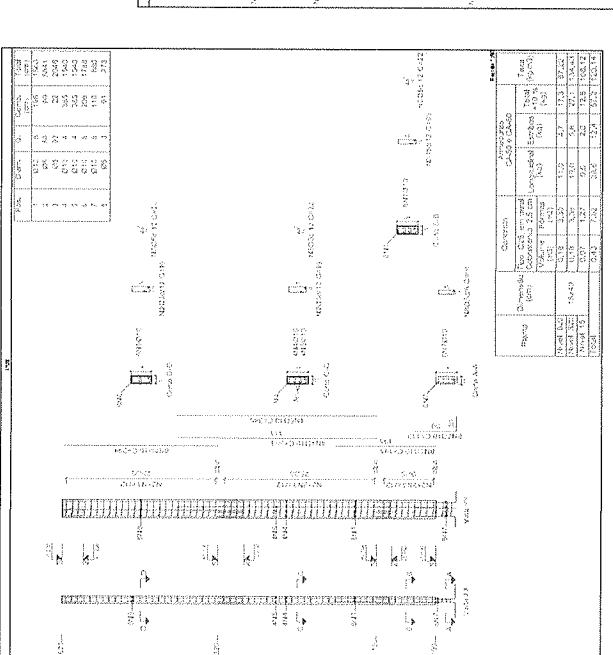
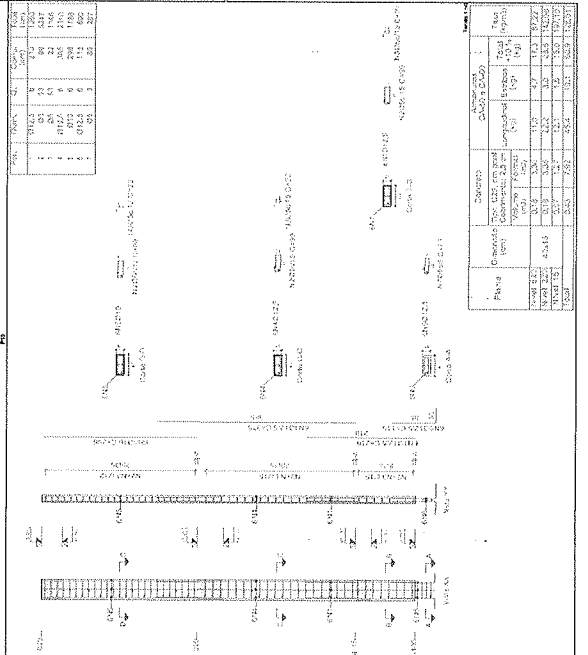

Responsável Técnico: Eng.º Civil nº 123456
 Responsável Legal: Eng.º Civil nº 123456
 Empresa: S.A. Engenharia e Projetos Ltda.
 Rua: Rua das Flores, 123 - Bairro: Centro - Cidade: Limoeiro do Norte - RN - CEP: 59.100-000
 Telefone: (51) 3333-3333 - E-mail: contato@empresa.com.br